

SKM600GM12M7



SEMITRANS® 3

IGBT M7 Modules

SKM600GM12M7

Features*

- $V_{CE(sat)}$ with positive temperature coefficient
- High overload capability
- Low loss, high density IGBTs
- Fast & soft switching inverse CAL diodes
- Large clearance (10 mm) and creepage distance (20 mm)
- Insulated copper baseplate using DCB Technology (Direct Copper Bonding)
- With integrated gate resistor

Typical Applications

- Matrix inverter
- Bidirectional switch

Remarks

- Max case temperature limited to $T_c = T_s = 125^\circ\text{C}$
- Product reliability results are valid for $T_j = 150^\circ\text{C}$ (recommended $T_{j,op} = -40 \dots +150^\circ\text{C}$)
- For storage and case temperature with TIM see document: "Technical Explanations Thermal Interface materials"

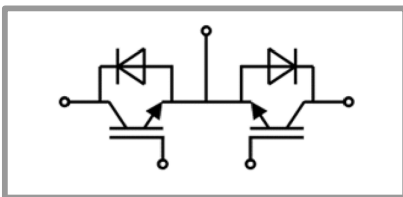

GM

Absolute Maximum Ratings			
Symbol	Conditions	Values	Unit
IGBT			
V_{CES}	$T_j = 25^\circ\text{C}$	1200	V
I_C	$T_j = 175^\circ\text{C}$	$T_c = 25^\circ\text{C}$	779
		$T_c = 80^\circ\text{C}$	591
I_{Cnom}		600	A
I_{CRM}		1200	A
V_{GES}		-20 ... 20	V
t_{psc}	$V_{CC} = 800\text{ V}$ $V_{GE} \leq 15\text{ V}$ $V_{CES} \leq 1200\text{ V}$	$T_j = 150^\circ\text{C}$	8
T_j			-40 ... 175
Inverse diode			
V_{RRM}	$T_j = 25^\circ\text{C}$	1200	V
I_F	$T_j = 175^\circ\text{C}$	$T_c = 25^\circ\text{C}$	688
		$T_c = 80^\circ\text{C}$	513
I_{FRM}		1200	A
I_{FSM}	$t_p = 10\text{ ms, sin } 180^\circ, T_j = 25^\circ\text{C}$	3240	A
T_j			-40 ... 175
Module			
$I_{t(RMS)}$		500	A
T_{stg}	module without TIM	-40 ... 125	$^\circ\text{C}$
V_{isol}	AC sinus 50 Hz, $t = 1\text{ min}$	4000	V

Characteristics					
Symbol	Conditions	min.	typ.	max.	Unit
IGBT					
$V_{CE(sat)}$	$I_C = 600\text{ A}$ $V_{GE} = 15\text{ V}$ chipelevel	$T_j = 25^\circ\text{C}$	1.55	1.88	V
		$T_j = 150^\circ\text{C}$	1.80		V
V_{CE0}	chipelevel	$T_j = 25^\circ\text{C}$	0.87	0.95	V
		$T_j = 150^\circ\text{C}$	0.76		V
r_{CE}	$V_{GE} = 15\text{ V}$ chipelevel	$T_j = 25^\circ\text{C}$	1.13	1.55	m Ω
		$T_j = 150^\circ\text{C}$	1.73		m Ω
$V_{GE(th)}$	$V_{CE} = 10\text{ V, } I_C = 60\text{ mA}$	5.4	6	6.6	V
I_{CES}	$V_{GE} = 0\text{ V, } V_{CE} = 1200\text{ V, } T_j = 25^\circ\text{C}$			5	mA
C_{ies}	$V_{CE} = 10\text{ V}$ $V_{GE} = 0\text{ V}$	$f = 1\text{ MHz}$	120		nF
C_{oes}		$f = 1\text{ MHz}$	3.66		nF
C_{res}		$f = 1\text{ MHz}$	1.28		nF
Q_G	$V_{GE} = -8\text{ V} \dots +15\text{ V}$		5360		nC
R_{Gint}	$T_j = 25^\circ\text{C}$		0.8		Ω
$t_{d(on)}$	$V_{CC} = 600\text{ V}$ $I_C = 600\text{ A}$ $V_{GE} = +15/-15\text{ V}$	$T_j = 150^\circ\text{C}$	260		ns
t_r		$T_j = 150^\circ\text{C}$	85		ns
E_{on}	$R_{Gon} = 1.2\ \Omega$	$T_j = 150^\circ\text{C}$	57		mJ
$t_{d(off)}$	$R_{Goff} = 1\ \Omega$	$T_j = 150^\circ\text{C}$	436		ns
t_f	$di/dt_{on} = 8000\text{ A}/\mu\text{s}$ $di/dt_{off} = 5240\text{ A}/\mu\text{s}$ $dv/dt = 5960\text{ V}/\mu\text{s}$	$T_j = 150^\circ\text{C}$	95		ns
E_{off}		$T_j = 150^\circ\text{C}$	68		mJ
$R_{th(j-c)}$	per IGBT			0.066	K/W
$R_{th(c-s)}$	per IGBT, P12 (reference)		0.037		K/W
$R_{th(c-s)}$	per IGBT, HP-PCM		0.02		K/W

SKM600GM12M7



SEMITRANS® 3

IGBT M7 Modules

SKM600GM12M7

Features*

- $V_{CE(sat)}$ with positive temperature coefficient
- High overload capability
- Low loss, high density IGBTs
- Fast & soft switching inverse CAL diodes
- Large clearance (10 mm) and creepage distance (20 mm)
- Insulated copper baseplate using DCB Technology (Direct Copper Bonding)
- With integrated gate resistor

Typical Applications

- Matrix inverter
- Bidirectional switch

Remarks

- Max case temperature limited to $T_c = T_s = 125^\circ\text{C}$
- Product reliability results are valid for $T_j = 150^\circ\text{C}$ (recommended $T_{j,op} = -40\dots+150^\circ\text{C}$)
- For storage and case temperature with TIM see document: "Technical Explanations Thermal Interface materials"

Characteristics						
Symbol	Conditions		min.	typ.	max.	Unit
Inverse diode						
$V_F = V_{EC}$	$I_F = 600\text{ A}$ $V_{GE} = 0\text{ V}$ chipelevel	$T_j = 25^\circ\text{C}$		2.14	2.46	V
		$T_j = 150^\circ\text{C}$		2.07		V
V_{F0}	chipelevel	$T_j = 25^\circ\text{C}$		1.30	1.50	V
		$T_j = 150^\circ\text{C}$		0.90		V
r_F	chipelevel	$T_j = 25^\circ\text{C}$		1.40	1.60	m Ω
		$T_j = 150^\circ\text{C}$		1.95		m Ω
I_{RRM}	$V_{CC} = 600\text{ V}$	$T_j = 150^\circ\text{C}$		555		A
Q_{rr}	$I_F = 600\text{ A}$ $V_{GE} = -15\text{ V}$	$T_j = 150^\circ\text{C}$		92		μC
E_{rr}	$di/dt_{off} = 8000\text{ A}/\mu\text{s}$	$T_j = 150^\circ\text{C}$		43		mJ
$R_{th(j-c)}$	per diode				0.09	K/W
$R_{th(c-s)}$	per diode, P12 (reference)			0.038		K/W
$R_{th(c-s)}$	per diode, HP-PCM			0.021		K/W
Module						
L_{CE}				31		nH
R_{CC+EE}	measured per switch	$T_j = 25^\circ\text{C}$		0.55		m Ω
		$T_j = 150^\circ\text{C}$		0.85		m Ω
$R_{th(c-s)1}$	calculated without thermal coupling, P12 (reference)			0.0093		K/W
$R_{th(c-s)2}$	including thermal coupling, T_s underneath module, P12 (reference)			0.015		K/W
$R_{th(c-s)2}$	including thermal coupling, T_s underneath module, HP-PCM			0.0078		K/W
M_s	to heat sink M6		3		5	Nm
M_t	to terminal M5		2.5		5	Nm
				-		Nm
w					325	g

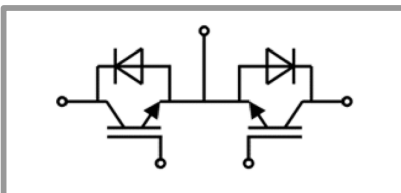

GM

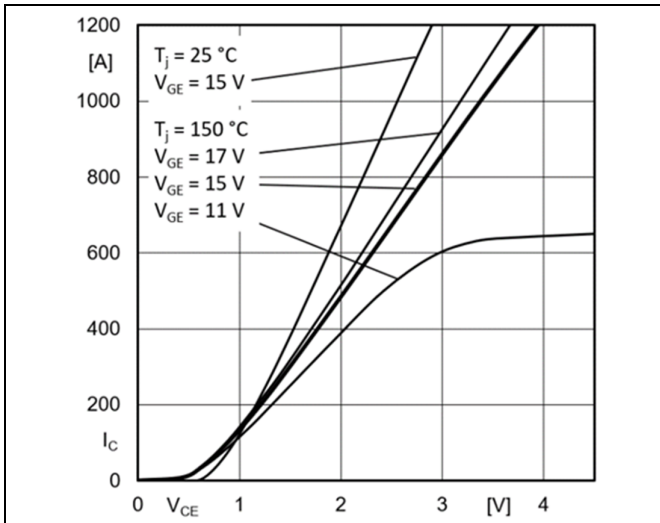

Fig. 1: Typ. output characteristic, inclusive $R_{CC+EE'}$

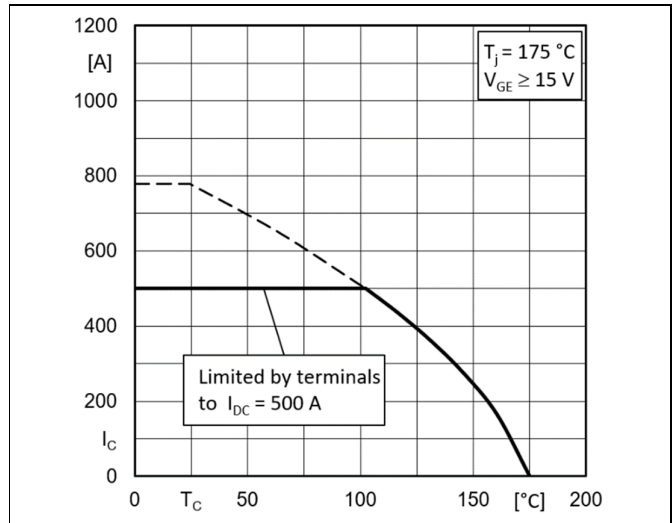

Fig. 2: Rated current vs. temperature $I_C = f(T_C)$

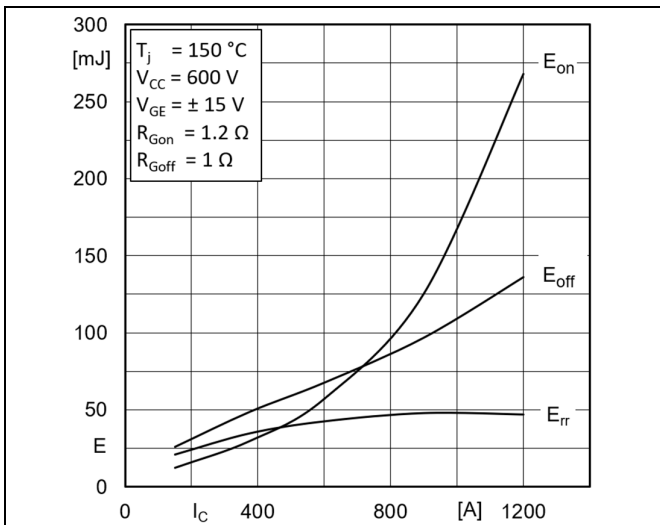

Fig. 3: Typ. turn-on /-off energy = $f(I_C)$

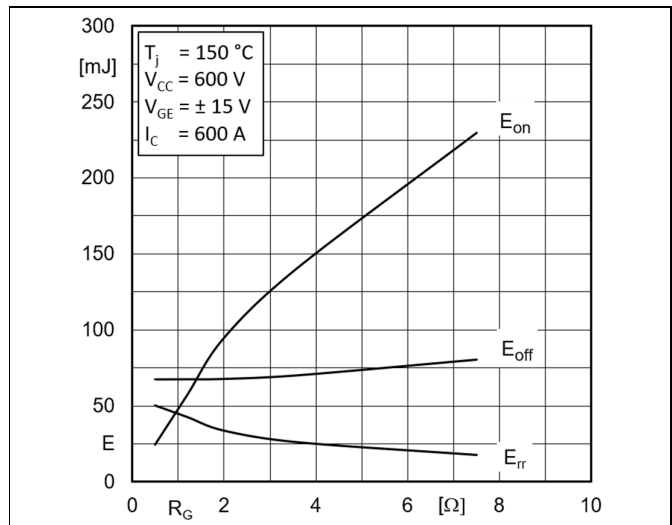

Fig. 4: Typ. turn-on /-off energy = $f(R_G)$

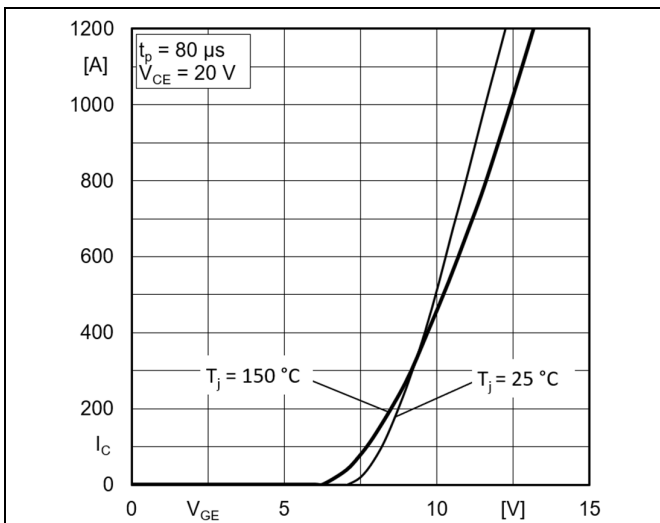

Fig. 5: Typ. transfer characteristic

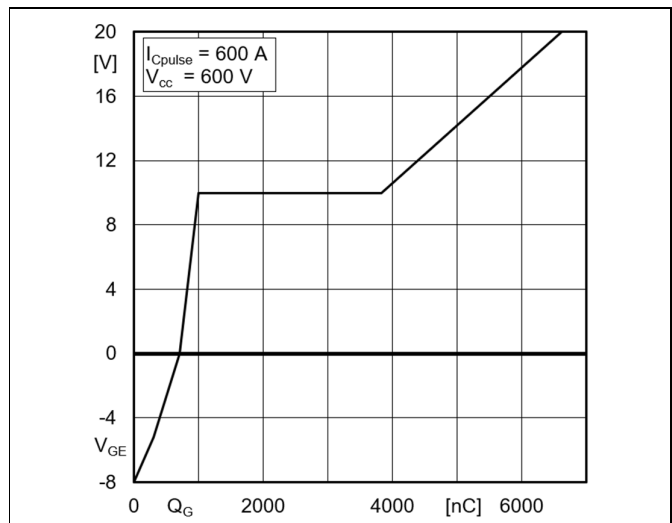

Fig. 6: Typ. gate charge characteristic

SKM600GM12M7

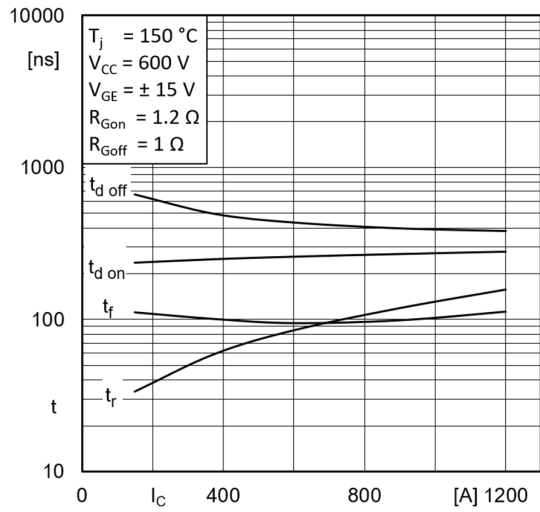

Fig. 7: Typ. switching times vs. I_c

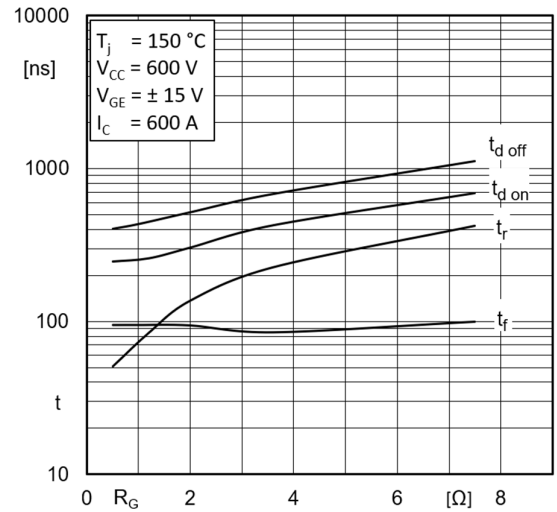

Fig. 8: Typ. switching times vs. gate resistor R_G

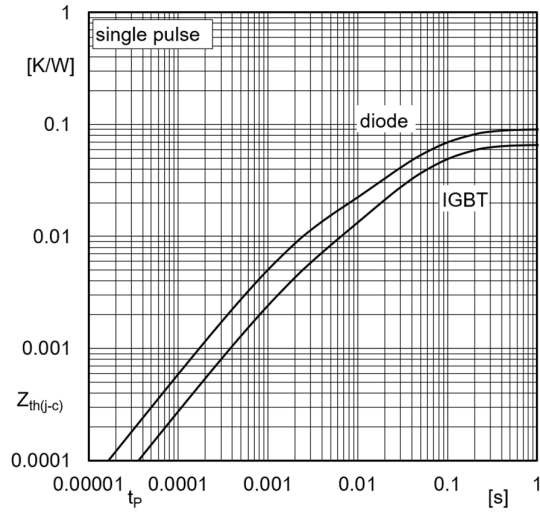

Fig. 9: Transient thermal impedance

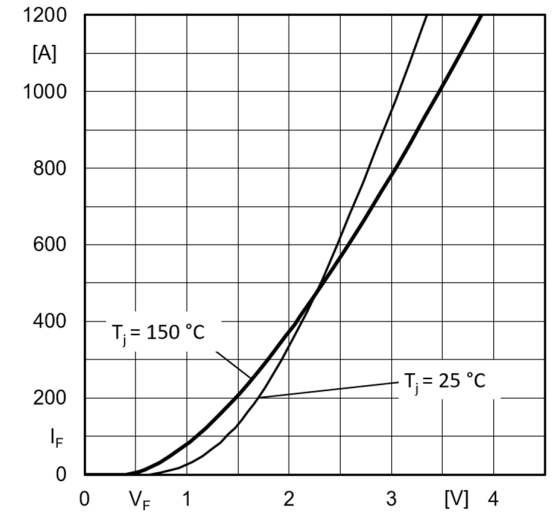

Fig. 10: Typ. CAL diode forward charact., incl. R_{CC+EE}

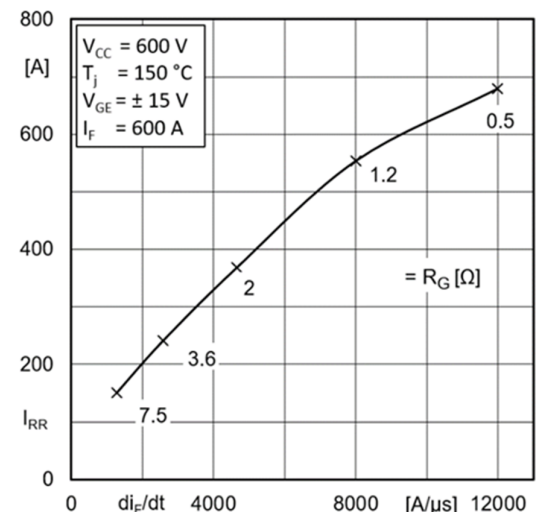

Fig. 11: CAL diode peak reverse recovery current

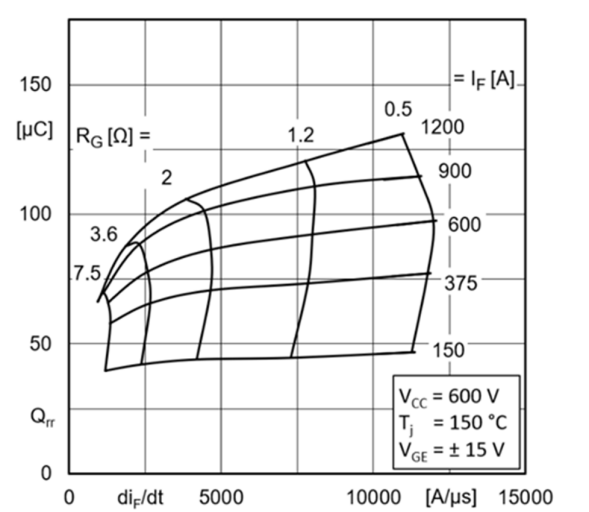
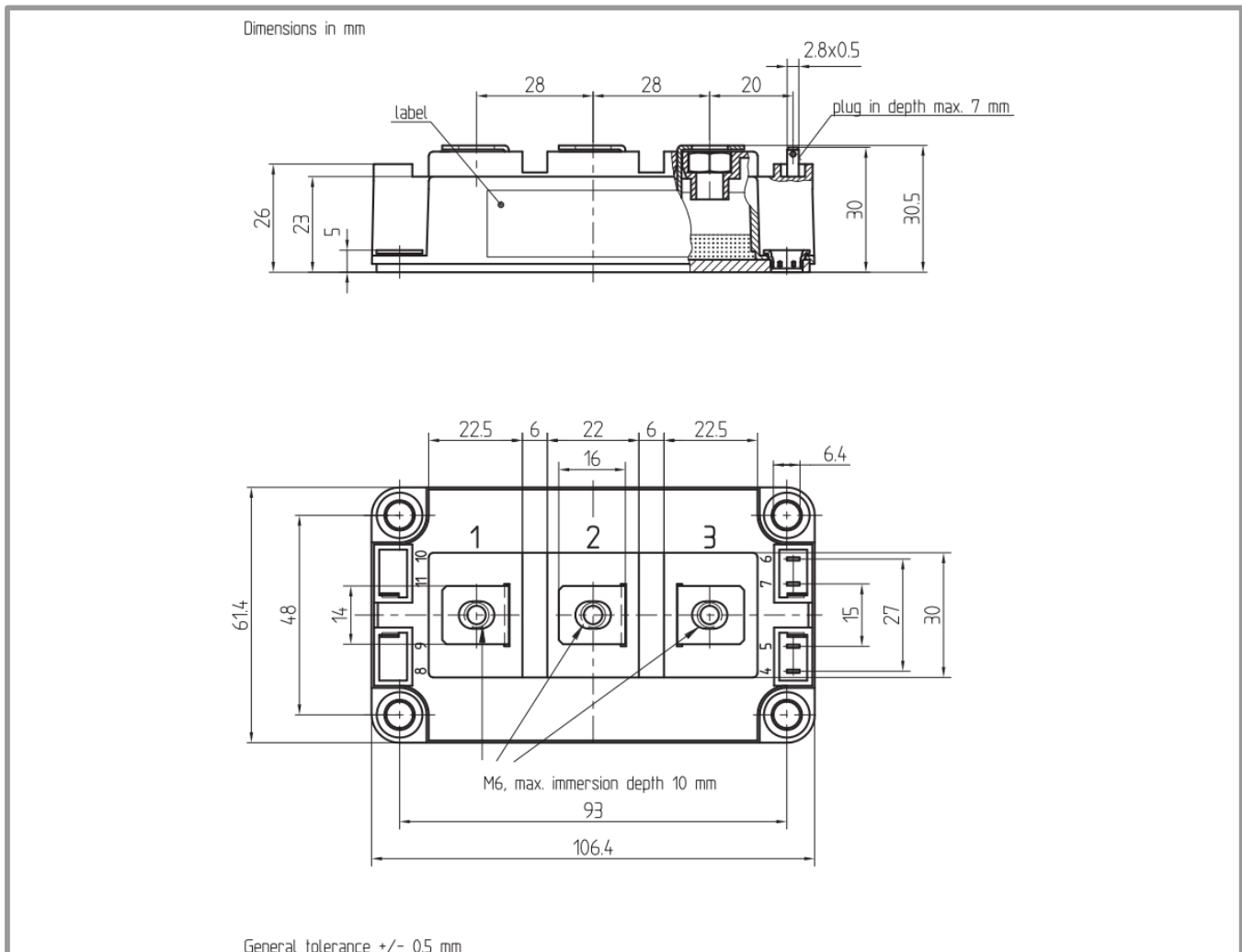
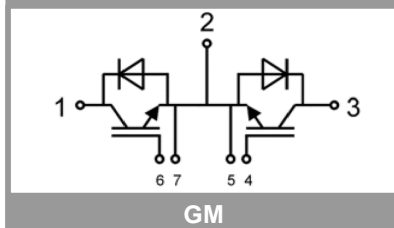

Fig. 12: Typ. CAL diode peak reverse recovery charge



Pinout and Dimensions



This is an electrostatic discharge sensitive device (ESDS) according to international standard IEC 61340.

*IMPORTANT INFORMATION AND WARNINGS

The specifications of SEMIKRON products may not be considered as any guarantee or assurance of product characteristics ("Beschaffenheitsgarantie"). The specifications of SEMIKRON products describe only the usual characteristics of SEMIKRON products to be expected in typical applications, which may still vary depending on the specific application. Therefore, products must be tested for the respective application in advance. Resulting from this, application adjustments of any kind may be necessary. Any user of SEMIKRON products is responsible for the safety of their applications embedding SEMIKRON products and must take adequate safety measures to prevent the applications from causing any physical injury, fire or other problem, also if any SEMIKRON product becomes faulty. Any user is responsible for making sure that the application design and realization are compliant with all laws, regulations, norms and standards applicable to the scope of application. Unless otherwise explicitly approved by SEMIKRON in a written document signed by authorized representatives of SEMIKRON, SEMIKRON products may not be used in any applications where a failure of the product or any consequences of the use thereof can reasonably be expected to result in personal injury. No representation or warranty is given and no liability is assumed with respect to the accuracy, completeness and/or use of any information herein, including without limitation, warranties of non-infringement of intellectual property rights of any third party. SEMIKRON does not convey any license under its or a third party's patent rights, copyrights, trade secrets or other intellectual property rights, neither does it make any representation or warranty of non-infringement of intellectual property rights of any third party which may arise from a user's applications. Due to technical requirements our products may contain dangerous substances. For information on the types in question please contact the nearest SEMIKRON sales office. This document supersedes and replaces all previous SEMIKRON information of comparable content and scope. SEMIKRON may update and/or revise this document at any time.